

SELF-ACTING TEMPERATURE REGULATORS TR25/R (Reverse action for cooling systems)

DESCRIPTION

The ADCATrol TR25/R valves series are designed for temperature control in cooling systems where the valve opens with temperature rise. They are single seated, unbalanced and intended to be coupled with T series thermostat models T.205 and T.405. The liquid filling the thermostat expands when the temperature of the fluid being cooled rises, opening the valve.

MAIN FEATURES

Easily adjustable temperature range.
Proportional temperature control.
Single seated, two way, reverse acting valve.
Built-in strainer.
Narrow thermostat neutral zone (1,5 to 2,5 °C).
No special tools required for servicing.
Stuffing box is an integral part of the thermostatic element, allowing easy and simple maintenance of the valve.

OPTIONS: PK sensor pocket.
Different capillary lengths.
Other thermostats on request.

USE: Water, air and other gases and liquids compatible with the construction.

AVAILABLE MODELS: TR25S/R – carbon steel.
TR25i/R – stainless steel.

AVAILABLE THERMOSTATS: T.205 – 400 N (max. closing force).
T.405 – 500 N (max. closing force).

SIZES: 1/2" to 1"; DN 15 to DN 25.

CONNECTIONS: Female threaded ISO 7 Rp or NPT.
Flanged EN 1092-1 PN 40.

THERMOSTAT RANGES: T.205: 0 to 60 °C, 30 to 90 °C and 60 to 120 °C.
T.405: 0 to 120 °C and 40 to 160 °C.

INSTALLATION: Horizontal installation with the thermostat in the vertical position, in order to reduce wear.
A "Y" strainer should be installed upstream of the valve.
See IMI – Installation and maintenance instructions.

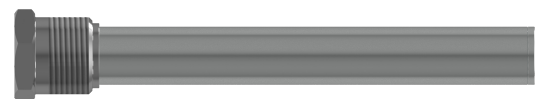
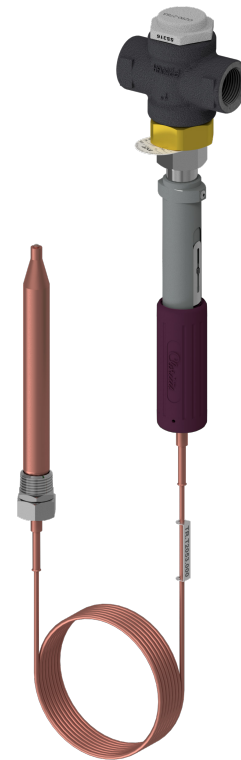

Optional PK sensor pocket

CE MARKING – GROUP 2 (PED – EUROPEAN DIRECTIVE)

PN 40	CATEGORY
1/2" to 1" – DN 15 to 25	SEP

BODY LIMITING CONDITIONS

PN 40 ALLOWABLE PRESSURE	RELATED TEMPERATURE
40 bar	120 °C
24 bar	350 °C

Minimum operating temperature: -10 °C.
Maximum operating temperature: 150 °C.

TR25 – T SERIES THERMOSTATS – FTO, UNBALANCED TRIM, METAL SEALING (CLASS IV)

MODEL	SIZE	SEAT Ø (mm)	Kvs (m³/h)	STROKE (mm)	MAXIMUM PERMISSIBLE PRESSURE DROP (bar)	
					T.205	T.405
TR25 – 15/15	1/2" – DN 15	15	1,9	6	15	20
TR25 – 20/15	3/4" – DN 20	15	1,9	6,5	15	20
TR25 – 20/20	3/4" – DN 20	20	4,2	6,5	9	12
TR25 – 25/20	1" – DN 25	20	4,2	7	9	12

PROPORTIONAL BAND

The proportional band is the temperature change required for the valve to move from its fully open to fully closed position. It depends on the valve stroke (mm) and on the thermostat movement per °C (mm/°C), and is calculated as follows:

$$\text{Proportional band} = \frac{\text{Valve stroke (mm)}}{\text{Thermostat movement (mm/°C)}}$$

Thermostat movement for T.205 and T.405: 0,5 mm/°C.

A proportional band between 8 °C and 13 °C is suitable for most applications. A smaller proportional band is not ideal when heat loads vary rapidly.

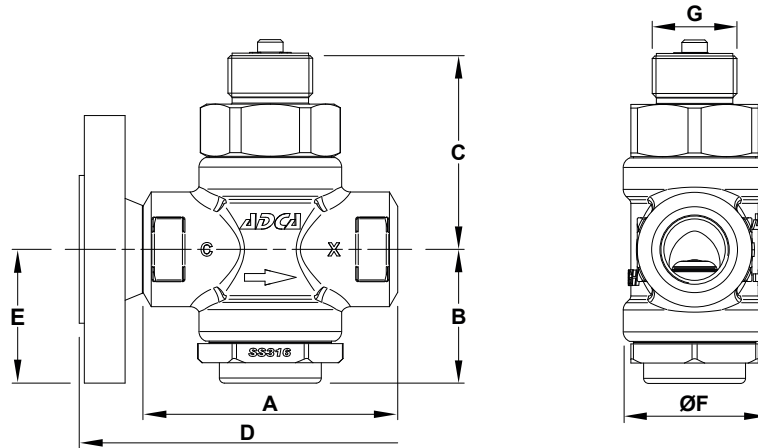

DIMENSIONS – VALVE BODY (mm)

SIZE	THREADED						PN 40		
	A	B	C	ØF	G	WEIGHT (kg)	D	E	WEIGHT (kg)
1/2" – DN 15	90	38	71	57	1"	1,5	130	48	2,9
3/4" – DN 20	90	38	71	57	1"	1,4	150	53	3,5
* 3/4" – DN 20	100	44	76	57	1"	1,9	150	53	3,9
1" – DN 25	100	44	76	57	1"	1,9	160	58	4,2

* TR25 – 20/20 model only.

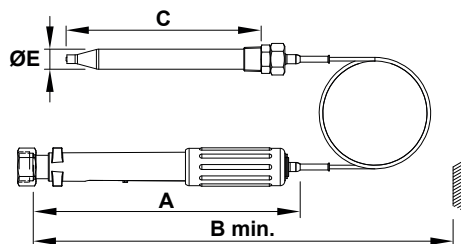

DIMENSIONS – THERMOSTAT (mm)

MODEL	A	B	C	ØE	WEIGHT (kg)
T.205	305	405	210	22	1,8
T.405	385	525	390	22	2,6

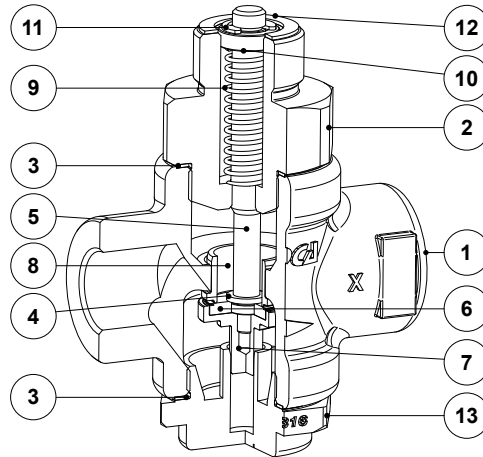

MATERIALS			
POS. No.	DESIGNATION	TR25S/R	TR25i/R
1	Body	P250GH / 1.0460	AISI 316 / 1.4401
2	Bonnet	C45E / 1.1191	AISI 316 / 1.4401; AISI 303 / 1.4305
3	* Gasket	Stainless steel / Graphite	Stainless steel / Graphite
4	Washer	Stainless steel A2	Stainless steel A2
5	* Stem	AISI 303 / 1.4305	AISI 303 / 1.4305
6	* Valve head	EPDM	EPDM
7	* Valve plug	AISI 316 / 1.4401	AISI 316 / 1.4401
8	Seat	AISI 303 / 1.4305	AISI 303 / 1.4305
9	* Spring	AISI 302 / 1.4310	AISI 302 / 1.4310
10	* Spacer ring	AISI 304 / 1.4301	AISI 304 / 1.4301
11	* Retaining ring	Stainless steel A2	Stainless steel A2
12	* Gasket	Stainless steel / Graphite	Stainless steel / Graphite
13	Bottom cover	AISI 351 CF8M / 1.4408	AISI 351 CF8M / 1.4408

* Available spare parts.

PK SENSOR POCKETS

Sensor pockets made of stainless steel can be supplied with all TR series self-acting thermostats using rod sensors. A sensor pocket, also called thermowell, is used to protect the sensor and to allow its removal while the plant is running or, e.g., the tank where it is connected to is full.

The use of sensor pockets implies delay of heat transfer to the rod sensors and, thus, a longer thermostat reaction time. This is, to some extent, counteracted by filling up the sensor pockets with a thermal conductive paste or glycerine.



DIMENSIONS (mm)					
MODEL	ØD	H	L	R	SW
PK2	25	9	218	1"	36
PK4	25	10	390	1 1/4"	46

MATERIAL: AISI 316 / 1.4401.

INSTALLATION: The installation site for the sensor pocket is arbitrary when paste is applied. When glycerine is used, the sensor pocket must point at least slightly downwards.